

■ N-Channel Enhancement MOSFET

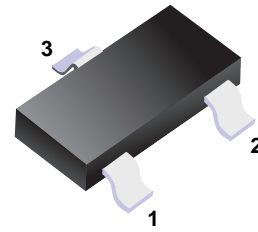

- 1. Gate
- 2. Source
- 3. Drain

■ Simplified outline(SOT-23)

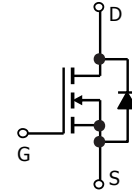

■ Marking Code:2300

MAXIMUM RATINGS (TA=25°C unless otherwise noted)

Symbol	Parameter	Value	Units
V _{DS}	Drain-Source voltage	20	V
V _{GS}	Gate-Source voltage	±10	V
I _D	Drain current	4	A
P _D	Power Dissipation	1.25	W
T _j	Junction Temperature	150	°C
T _{stg}	Storage Temperature	-55-150	°C

ELECTRICAL CHARACTERISTICS (T_{amb}=25°C unless otherwise specified)

Parameter	Symbol	Test conditions	MIN	TYP	MAX	UNIT
Drain-Source Breakdown Voltage	V _{(BR)DSS}	V _{GS} =0V, I _D =250μA	20			V
Gate-Threshold Voltage	V _{th(GS)}	V _{DS} = V _{GS} , I _D =250 μA	0.5	0.70	1.0	V
Gate-body Leakage	I _{GSS}	V _{DS} =0V, V _{GS} =±10V			±100	nA
Zero Gate Voltage Drain Current	I _{DSS}	V _{DS} =20V, V _{GS} =0V			1	μA
Drain-Source On-Resistance	r _{D(S)ON}	V _{GS} =2.5V, I _D =4.0A		27	35	mΩ
		V _{GS} =4.5V, I _D =5.0A		20	27	mΩ
Forward Trans conductance	g _{fs}	V _{DS} =5V, I _D =5.8A		25		S
Dynamic Characteristics						
Input Capacitance	C _{iss}	V _{DS} =10V, V _{GS} =0V, f=1MHz		515		pF
Output Capacitance	C _{oss}			90		
Reverse Transfer Capacitance	C _{rss}			72		
Switching Capacitance						
Turn-on Delay Time	t _{d(on)}	V _{DD} =10V, R _L =1.7Ω, V _{GS} =10V R _{GEN} =3.0Ω		3		nS
Turn-on Rise Time	t _r			7.5		nS
Turn-off Delay Time	t _{d(off)}			20		nS
Turn-off Fall Time	t _f			6		nS
Total Gate Charge	Q _g	V _{DS} =10V, I _D =5.8A, V _{GS} =10V,		12		nC
Gate-Source Charge	Q _{gs}			1		nC
Gate-Drain Charge	Q _{gd}			2		nC
Drain-Source Diode Characteristics						
Diode Forward Voltage	V _{SD}	V _{GS} =0V, I _S =1A		0.75	1.2	V
Diode Forward Current	I _S				2.0	A

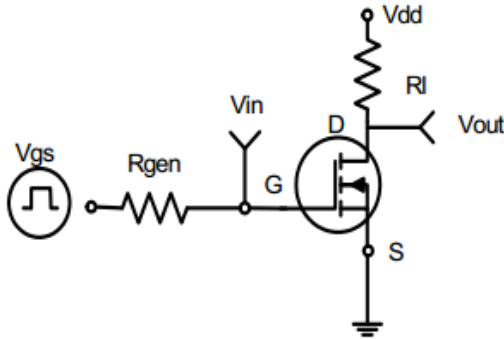

Figure 1: Switching Test Circuit

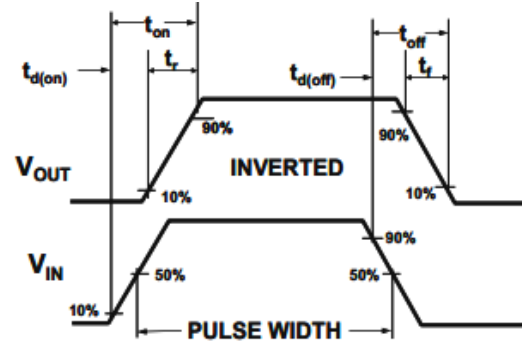

Figure 2: Switching Waveforms

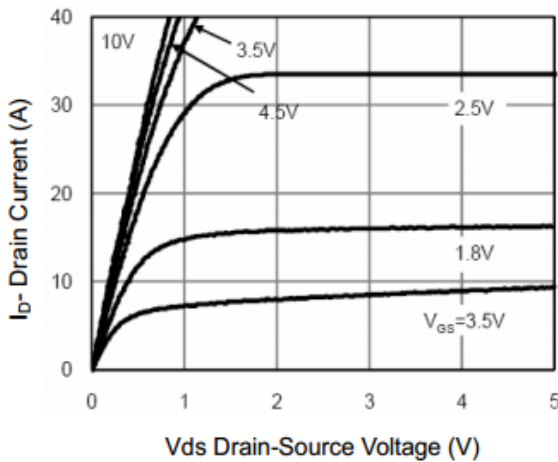

Figure 3 Output Characteristics

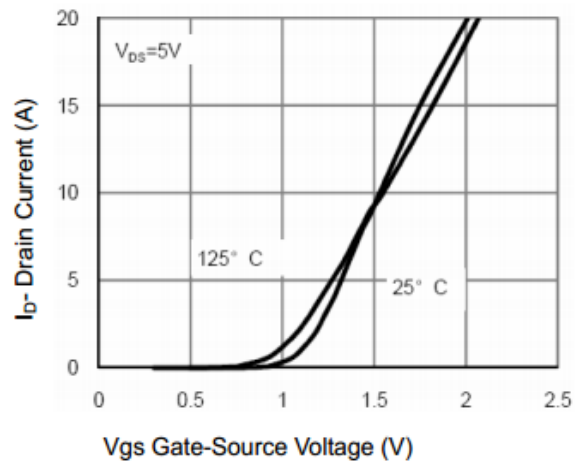

Figure 4 Transfer Characteristics

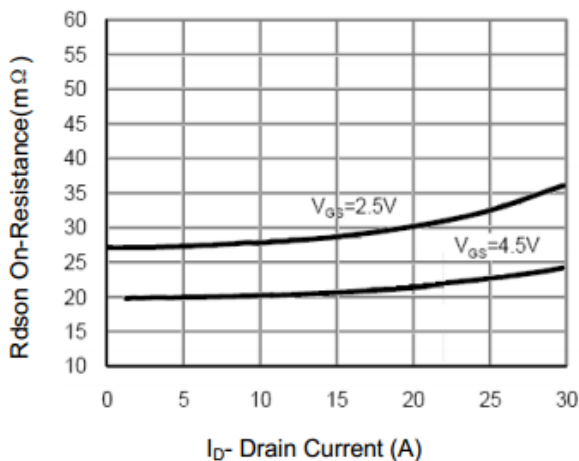

Figure 5 Drain-Source On-Resistance

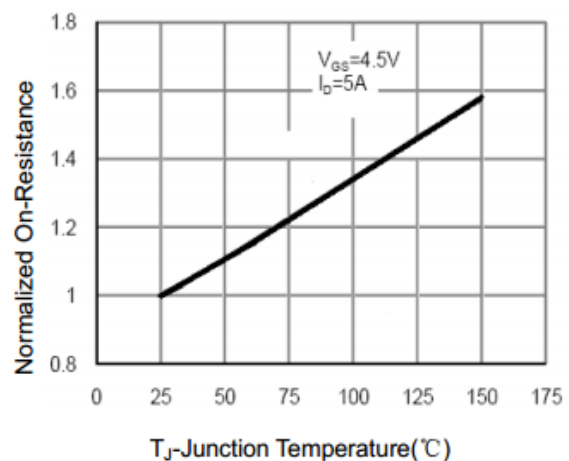
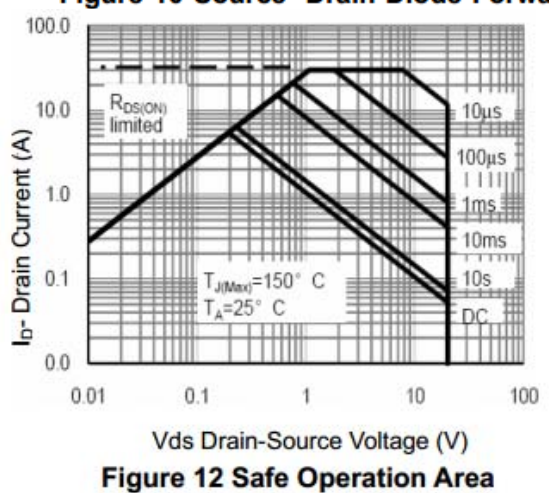
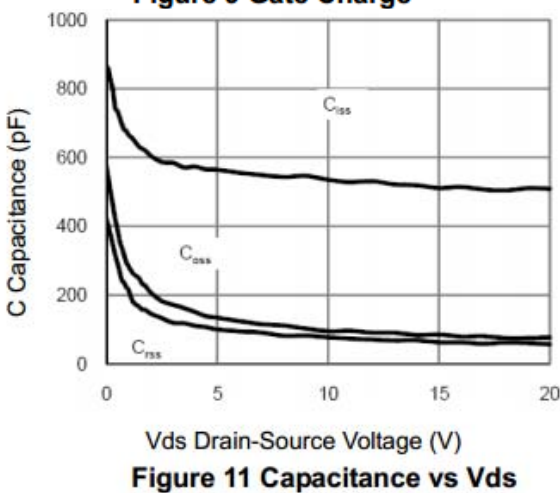
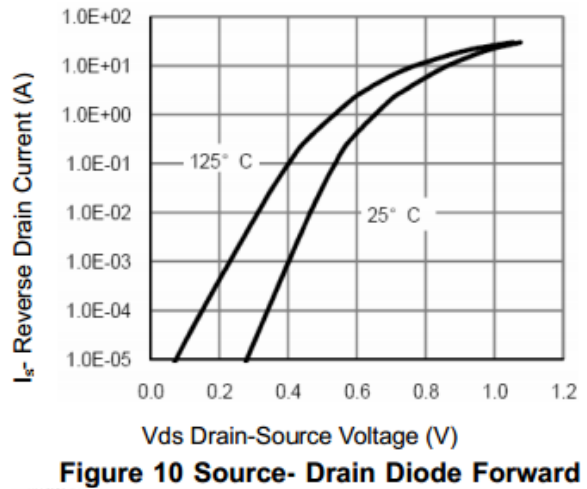
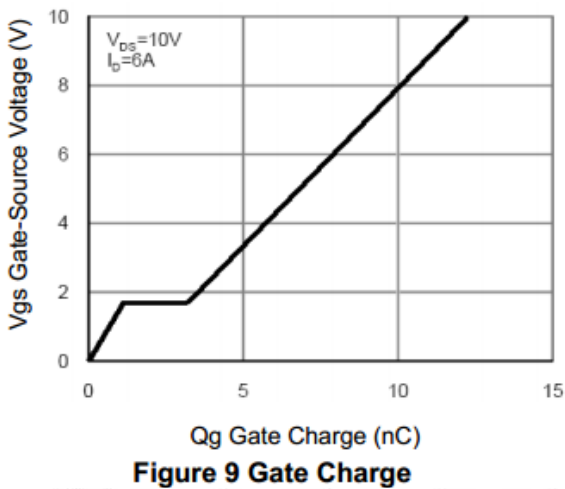
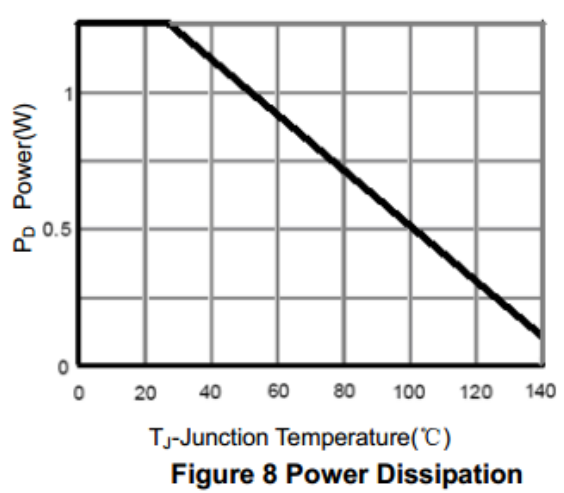
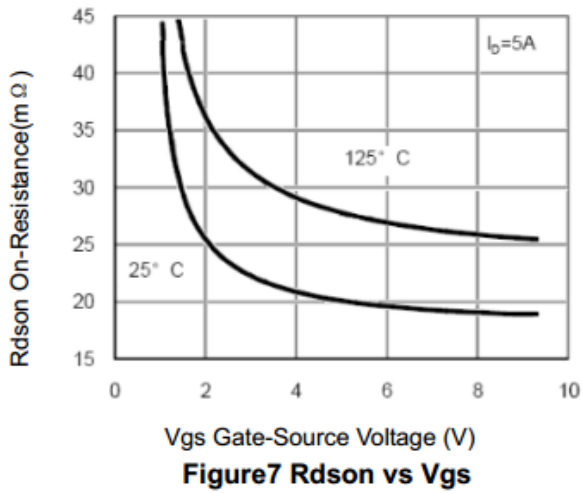
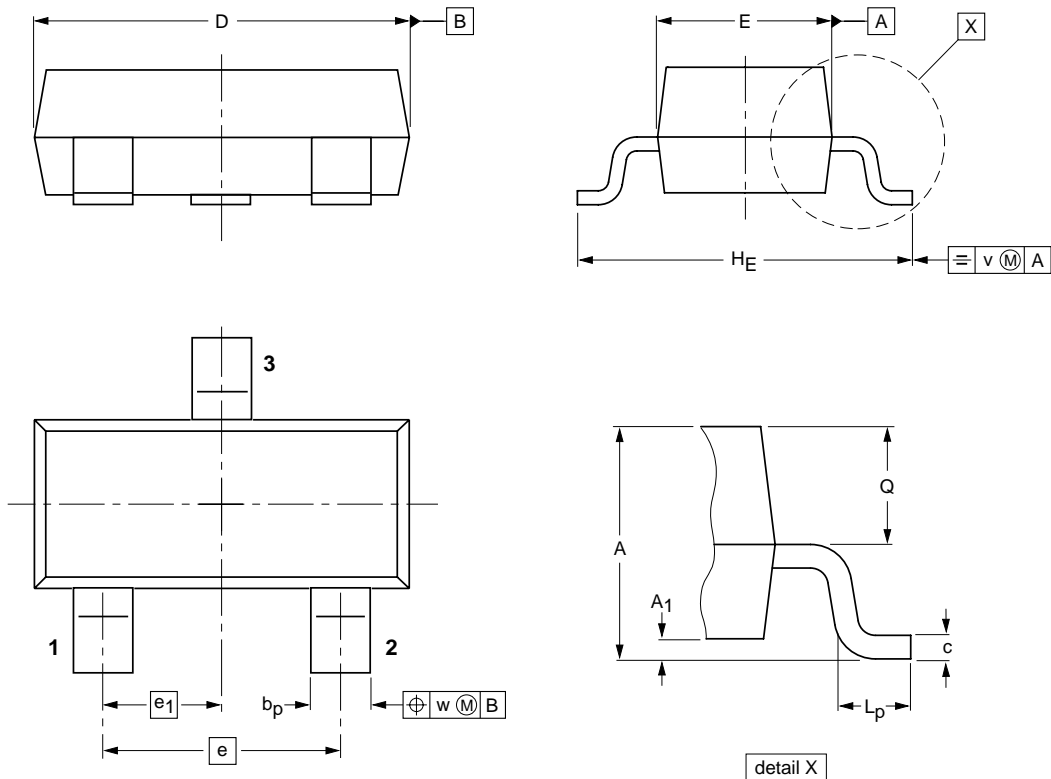

Figure 6 Drain-Source On-Resistance



Package Outline

SOT-23



DIMENSIONS (mm are the original dimensions)

UNIT	A	A ₁ max.	b _p	c	D	E	e	e ₁	H _E	L _p	Q	v	w
mm	1.1 0.9	0.1	0.48 0.38	0.15 0.09	3.0 2.8	1.4 1.2	1.9	0.95	2.5 2.1	0.45 0.15	0.55 0.45	0.2	0.1

Summary of Packing Options

Package	Packing Description	Packing Quantity	Industry Standard
SOT-23	Tape/Reel, 7" reel	3000	EIA-481-1